

INTELLIGENT MICROBEARINGS PROJECT WITH MEMORY OF STRESS-STRAIN HISTORY

Krzysztof Wierzcholski

*Maritime University Gdynia
Morska Street 81-87, 81-225 Gdynia, Poland
tel.:+48 58 6901348, fax:+48 58 6901399
e-mail: wierzch@am.gdynia.pl*

Andrzej Miszczak

*Maritime University Gdynia
Morska Street 81-87, 81-225 Gdynia, Poland
tel.:+48 58 6901348, fax:+48 58 6901399
e-mail: miszczak@am.gdynia.pl*

Krzysztof Kosowski

*Gdańsk University of Technology
G. Narutowicza Street 11/12, 80-952 Gdańsk, Poland
tel.:+48 58 347 1916, fax:+48 58 341 4712
e-mail: kosowski@pg.gda.pl*

Abstract

Taking into account the increasing need of intelligent micro-bearing with memory, this paper presents the optimization, simulation and practical application of operating parameters (load carrying capacity, friction forces, friction coefficient, wear), simulation for hydrodynamic HDD micro-bearing with curvilinear nano-grooved journal profile. One of the reason of such journal profile is that this journal profile contributes to the variation (an increase or decrease) the memory capacity of HDD drive operating on hydrodynamic micro-bearings. Such properties are very important and required in HDD micro-bearings.

A general theory of materials with memory is the theory developed by Noll and Koleman. The simple solid body and liquid theory presented in this paper is based on the assumption that stress is defined by a whole deformation history.

The changes of micro-bearing superficial surfaces presented in this paper are described by the process of changes of mass of a body system defined by non-classical intelligent oil and bearing material properties.

Scientific problems considered in the paper are focused on comparisons and practical applications of tribological processes which occur during fluid flow around cells lubrication on the nano-surfaces in bio-bearings as well as surfaces of micro-bearings used in micro-mechanisms.

Up to now, the dynamic behavior of HDD spindle system with fluid micro-bearings was considered by Jang at al. [7]. They simulated an increase in the memory capacity by increase in the bearing width and by application herringbone or spiral grooves on the sleeve and journal surfaces of HDD micro-bearings. After proposal contained in this project it is additionally possible to make capacity memory simulations by the various shapes of micro-bearing journal application.

Keywords: *Curvilinear grooved journals, micro bearing in computer disks, capacity memory simulations*

1. Introduction

The task of presented topic concerns the determining and practical applications of the pressure distribution, load carrying capacity friction forces, coefficient and wear determination in a super

thin layer of non-Newtonian, visco-elastic lubricant inside the slide micro-bearing or nano-bearing gaps for a cylindrical, conical, parabolic, hyperbolic shapes of journal ridged and grooved surfaces. Non- isothermal, unsteady and random flow conditions and thermal deformations of the micro- bearing and its sleeve are taken into account in numerous foregoing research [12]. This paper considers the dynamic behavior of micro-bearing and allows to compare obtained results with recently achievements of other authors [15]. The lubrication of micro-bearing surfaces is characterized by various geometries form and by non-Newtonian lubricants. The aim of the presented paper is to generalize the recently methods of the pressure, load carrying capacity, friction forces, friction coefficients and wear calculation in a thin layer of non-Newtonian, visco-elastic lubricant of slide micro-bearing gaps and make the practical applications of obtained results [1-2, 4-11, 13-15].

Lack of knowledge

The application of theoretical and computational model for representing the behavior of intelligent micro-bearing surfaces with respecting the load carrying capacity memory and history of deformation memory of micro-bearing surfaces have not examined so far. Scientific effort of the proposed challenge shall contribute to improvement of this process by delivering the hydrodynamic flow characteristics of the considered media with the use of CFD tools. Up to now, only some parameters of micro-bearing surfaces are kept under control (temperature, external and internal pressure values and flow rate) but without influences of memory properties of course. For such investigation the lubrication of micro-bearing should be improved. Moreover, the engineering support for load carrying capacity development during the lubrication is to be delivered.

What should be done

- to describe the oil flow in micro-bearing gap taking into account the congenial strain rate tensor of lubricant, growth strain rate tensor and lubricant dynamic viscosity changes in gap height direction,
- to show the rheological properties of liquids based on the assumptions that stress is defined by the whole deformation history and are valid the following concepts: determinism, local action, fading memory,
- to determine surface deformations taking into account the growth tensor of cartilage and tensor of stress influence on the bearing material changes,
- to determine the material coefficients on the experimental way, to describe the memory of deformation history and unknown changes caused by growth tensors activities.

Goal definition

The social and ethical impacts of such a challenge are given through the following goals:

- 1) improving the quality of computer micro-bearing reliability by (~25%),
- 2) enhancing the time of computer disks exploitation (~20%).

The second order goal is financial impact by time and cost saving (~2% and ~20% respectively).

To whom is it addressed?

Computer Hard Disk Driver producers, micro-turbine, micro-robots and micro-motors producers as well as computational fluid mechanics and control research are three main groups that the challenge is addressed to.

2. State of the art

On - going challenges

A coupled journal and thrust hydrodynamic bearing has been recently used in the precision

spindle of a computer hard disk drive (HDD), replacing the conventional ball bearings, due to its outstanding low noise and vibration characteristics [10]. In this application, herringbone grooves have the advantage of self-sealing which causes the lubricant to be pumped inward, and therefore, reduces side leakage. They also prevent whirl instability that is observed in the plain journal bearings at concentric operating conditions. Groove location causes the dynamic performances during the micro-bearing exploitation. Fig. 1a, b, present various examples of slide micro-bearing distributions occurring in computer hard disc driver.

Fig. 2a, b, c shows the cylindrical micro-bearing journal with symmetric and asymmetric herring bone grooves [2-3, 7, 10]. Fig. 3a, b, c shows the geometries of the grooves and ridges situated in circumferential or longitudinal directions on the journal and sleeve [2, 7, 10] located on the parabolic surface. Random conditions are taking into account.

Fig. 4a, b, c; Fig. 5a, b, c; Fig. 6a, b, c present the geometries of the grooves and ridges situated in circumferential or longitudinal directions on the journal and sleeve [2, 7, 10] located on the hyperbolic, conical an spherical surfaces respectively.

Micro-bearing has application in medical drill bits and hard disc driver HDD spindle medical systems [9, 10].

The HDB spindle samples have a shaft diameter 3.0 mm; rotational speed 20000 rpm; viscosity of 18 cP (0.018 Pas), radial clearance 3 micrometers, mass 27 g, mass moment of inertia 0.000167 kgm². The width of upper and lower journal bearing changes from 1.6 and 1.8 mm to 2.2 and 1.2 mm. The flow analysis of the viscoelastic lubricant, will be performed by means of the Helmholtz equation and the equations of continuity, motion and energy [4-5, 12-14]. The lubricant flow in bearing gap is generated by rotation of a parabolic journal. Bearing sleeve is motionless. The micro-bearing lubrication is characterized by the dynamic viscosity changes in thin gap-height direction.

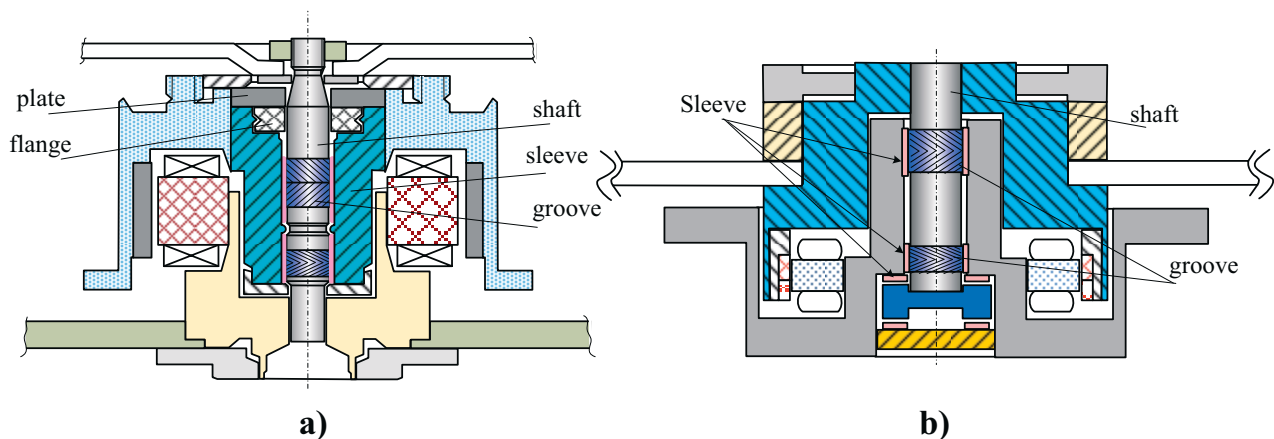

Fig. 1. Examples of slide micro-bearing arrangement in HDD drives: a) only journal bearing, b) thrust and journal bearing

Approaches for enhancing the state-of-the-art

The author suggest the following approaches to enhance the above described present situation: More realistic description of properties and working conditions of micro-bearing in computer disks by acquiring the necessary technical data on the micro-bearing behavior under exploitation from computer producers.

Making use of the recent developments of CFD computational tools and simulation techniques to optimize conditions for micro-bearing exploitation properties and to decrease costs of the process. To take into account a new scientific knowledge based on the memory of deformation history, features of intelligent non-Newtonian lubricant, as well as advanced mathematical description of hydrodynamic process occurring in them.

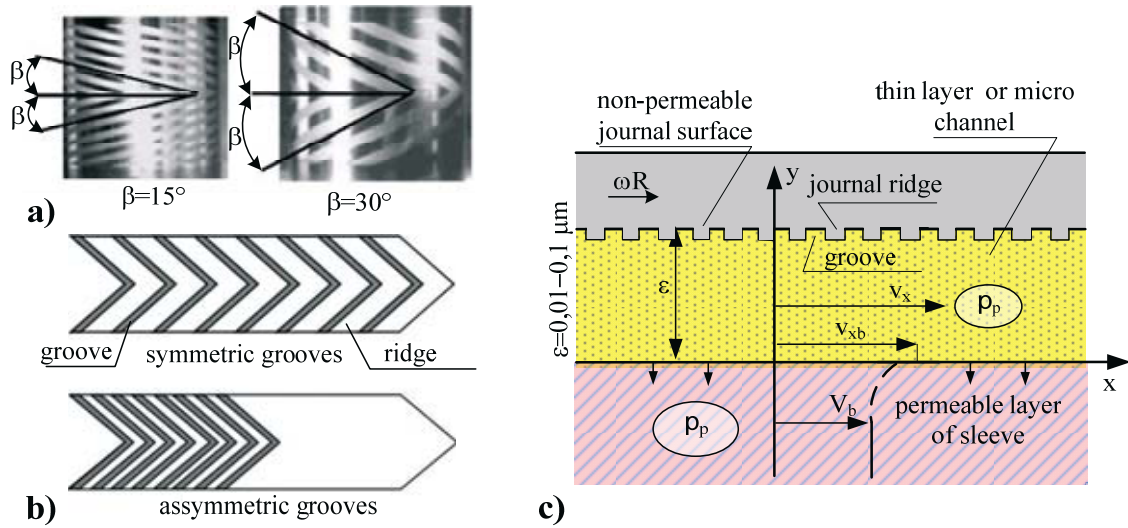

Fig. 2. The micro-bearing gap: a) various groove angles in journal, b) symmetric and asymmetric grooves, c) gap restricted by the permeable sleeve surface and the grooves in the micro-journal after G. H. Jang and J. W. Yoon [8]

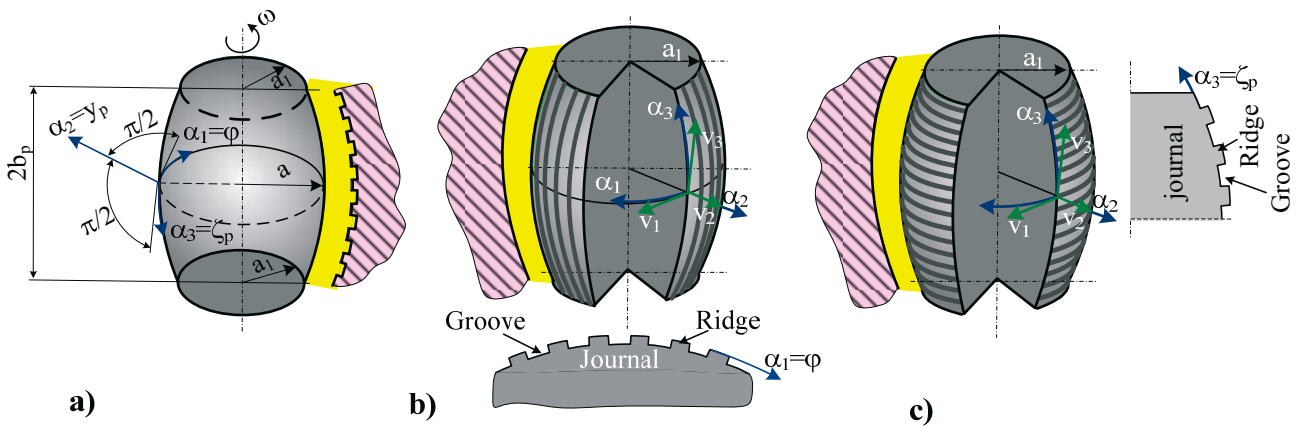

Fig. 3. Parabolic journal for hydrodynamic HDD micro-bearing (20 000 rpm after K.Ch. Wierzcholski): a) circumferential grooves on the parabolic sleeve, b) longitudinal grooves on the parabolic journal, c) circumferential grooves on the parabolic journal

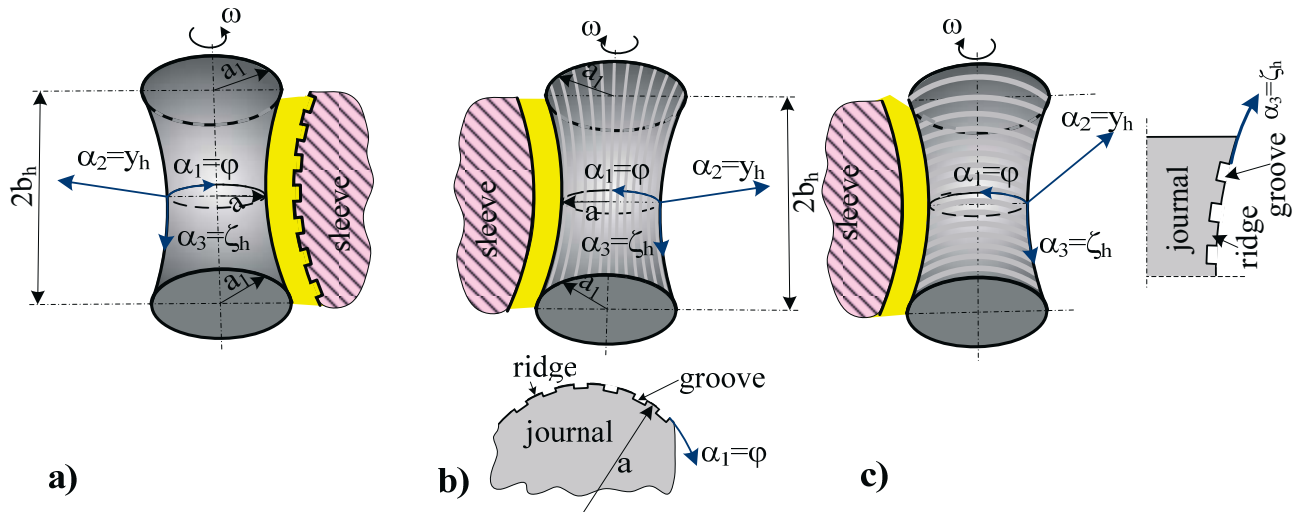

Fig. 4. Hyperbolic journal for hydrodynamic HDD micro-bearing (20 000 rpm after K.Ch. Wierzcholski): a) circumferential grooves on the hyperbolic sleeve, b) longitudinal grooves on the hyperbolic journal, c) circumferential grooves on the hyperbolic journal

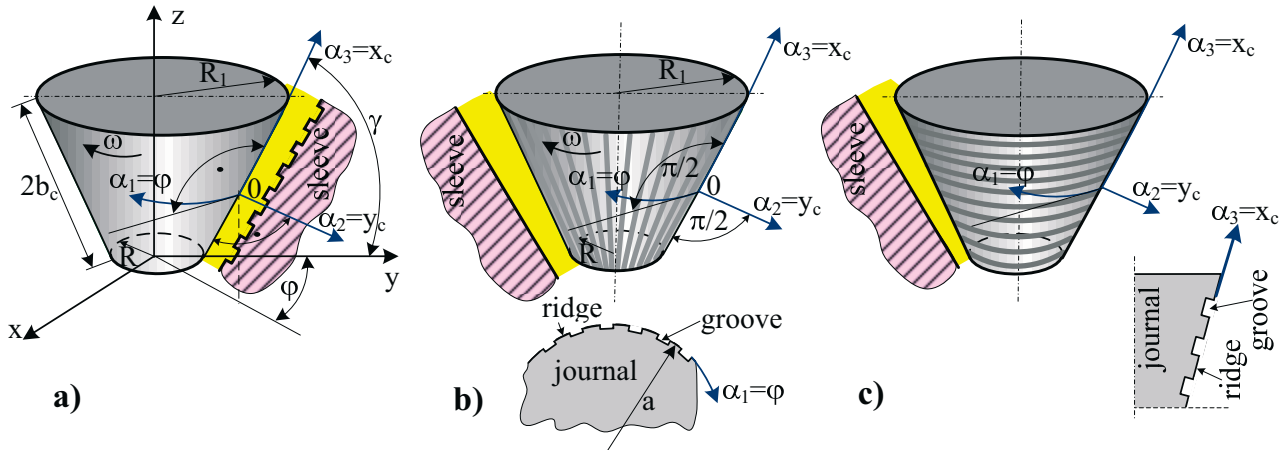

Fig. 5. Conical journal for hydrodynamic HDD micro-bearing (20 000rpm after K.Ch. Wiercholski):
 a) circumferential grooves on the conical sleeve, b) longitudinal grooves on the conical journal,
 c) circumferential grooves on the conical journal

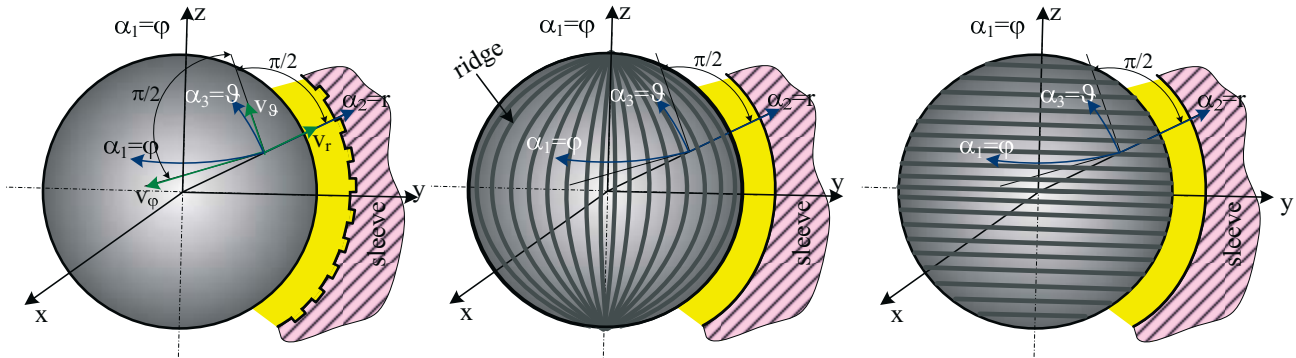

Fig. 6. Spherical journal for hydrodynamic HDD micro-bearing (20 000rpm after K.Ch. Wiercholski):
 a) circumferential grooves on the spherical sleeve, b) longitudinal grooves on the spherical journal,
 c) circumferential grooves on the spherical journal

These approaches will make possible to pass from extensive experimental research in the field of HDD-micro-bearing technology to novel analytical and numerical investigations and *vice versa*.

Scientific effort should contribute to the development process by providing with the data on the hydrodynamic lubrication flow characteristic in super thin boundary layer, obtained from computer optimization.

The liquid velocity components and pressure values should be determined, calculated, simulated and then optimally controlled. Boundary layer simplification has to be made for local flows. The unification of anticipated results by virtue of artificial neural network, random variables, stochastic methods and CFD tools are to be considered. The suggested approach also generalizes the obtained results by the virtue of random variables and stochastic methods for analysing the unsteady lubrication with memory of lubrication history.

The non - Newtonian viscoelastic lubricant properties and various journal shapes profile are to be taken into account to enhance the state of the present knowledge on the HDD micro-bearing lubrication because the friction forces which occur in the thin layer resting on the superficial layer of bearing surface will be taken into account, examined numerically and controlled.

The ultimate research and technological result of the proposed challenge is a prototype of intelligent micro-bearing, together with analytical and computational tools for further development and optimization of micro-bearing technology and equipment.

3. Research areas

The objectives of the proposed challenge is mainly related to nanotechnologies and nano-sciences, knowledge-based functional materials, as well as new production processes and devices, but particularly intelligent operating parameters and micro-bearing regeneration processes should be considered. In details, it addresses the following research domains:

1. Technologies associated with the micro-bearing lubrication

Multifunctional material

Intelligent micro-bearing enables utilization of radically innovative technologies and can lead to enormous benefits caused by the multifunctional lubrication. The proposed topic will focus on technological novelties and methods applied during the lubrication with relation to chemical and physical processes. To the innovative technologies is numbered a new oil with ferro-fluid additions and a new method of simultaneous control of the micro-bearing adaptation process. On their ground a new micro-bearing materials with better capacity to repair and regeneration and a new higher hardness and durability and lower friction coefficient, can be obtained.

Cell surface

A new achievement of this project is accounting for the super thin multifunctional layer of the oil film, produced after the new technology of lubrication. The multifunctional oil thin layer which arises in micro-bearing gap during the lubrication, is of great importance for the proper regeneration and memory process. The thickness of such film amounts from 10 to 100 nm. In such very thin layer boundary lubrication of the micro-bearing surface occurs because the velocity of the fluid particles simultaneously attains the value of about 100 nm/s. Such thin film has a radically new nanostructure with chemical and physical properties that significantly differ from those of conventional lubrications in classical technologies.

Tribology of non-conventional-materials

The thin boundary layer of the oil (produced by virtue of new technologies) cooperates with the thin superficial layer resting on the micro-bearing surface. These mutual tribological influences make it possible to obtain a greater load carrying capacity and smaller wear.

2. Engineering support for lubrication process of micro-bearing

Tribology of non-conventional-materials

The thin boundary layer of the oil (produced by virtue of new technologies) cooperates with the thin superficial layer resting on the micro-bearing surface. These mutual tribological influences make it possible to obtain a greater load carrying capacity and smaller wear.

3. Engineering support for lubrication process of micro-bearing

Nanoparticles in lubricant

The magnetic nano-particles are novel multifunctional materials of wide applications. The magnetic nano-particles introduced at first into thin fluid layer and further into superficial layer during the lubrication have two important aspects: miniaturisation - to include at least two functions in a small volume, and hybridisation - to gain from associating inorganic and organic components. Magnetic induction field in nano-scale at first improves lubrication and later increases the dynamic viscosity of the lubricant and increases human load carrying capacity.

Cognitive sciences

The proposed approach includes also introducing the intelligent micro-bearing, as well as related software generation by applying the optimal control theory and implementation of neuro-fuzzy methodology for creating the knowledge base of micro-bearing lubrication.

4. Conclusions

- After Author's calculations [12], a magnetic induction field increases the load carrying

capacity distributions in parabolic HDD micro-bearing by 6 percent at least, and—in some cases—even 10 percent and magnetic induction field decreases the values of friction coefficients [12].

- The journal motion produces the periodic hydrodynamic forces resulting from the rotating grooves on the parabolic shaft with various diameter. Hence the periodic load carrying capacity fixes the capacity memory. We can simulate the increases of the capacity memory of fluid dynamic HDD micro-bearings not only by the herringbone or spiral grooves indicated in papers [7], [10], but also by the various parabolic shapes of journal micro-bearings.
- The properties of the changes of memory capacity simulations in presented micro-bearing with parabolic journals are compared with the similar form for human bio-bearings with parabolic shapes of bone heads which are formed during the thousand years of evolution [12].

References

- [1] Asada, T., et al, *Hydrodynamic bearings and applied technologies*. Matsushita Tech, 46 (1), pp. 54-76, 2000.
- [2] Asada, T., Saito, H., Asaida, Y., Itoch, K., *Design of hydrodynamic bearing for high-speed HDD*. *Microsystem Technologies*, 8, pp. 220-226, 2002.
- [3] Bhushan, B., *Nano-tribology and nanomechanics of MEMS/NEMS and BioMEMS, BioNEMS materials and devices*. *Microelectronic Engineering*, 84, pp. 387-412, 2007.
- [4] Chizhik, S. A., Ahn, H. S., Chikunov, V. V., Suslov, A. A., *Tuning fork energy dissipation nanotribometry as option of AFM*, *Scanning Probe Microscopy*, pp. 119-121, 2004.
- [5] Chen, S. X., Zhang, Q. D., *Design of fluid bearing spindle motors with controlled unbalanced magnetic forces*. *IEEE Transactions on Magnetics*, 33 (5), pp. 2638-2640, 1997.
- [6] Gad-el-Hak, M., *The MEMS handbook*, CRC Press, 2001.
- [7] Jang, G. H., Lee, S. H., Kim, H. W., Kim, C. S., *Dynamic analysis of a HDD spindle system with FDBs due to the bearing width and asymmetric grooves of journal bearing*. *Microsystems Technologies*, 11, pp. 499-505, 2005.
- [8] Jang, G. H., Seo, C. H., Ho Scong Lee, *Finite element model analysis of an HDD considering the flexibility of spinning disc-spindle, head-suspension-actuator and supporting structure*. *Microsystem Technologies*, 13, pp. 837-847, 2007.
- [9] Jang, G. H., Park, S. J., Kim, C. S., Han, J. H., *Investigation of the electromechanical variables of the spindle motor and the actuator of HDD due to positioning and the free fall*. *Microsystem Technologies*, 13, pp. 797-809, 2007.
- [10] Jang, G. H., Yoon, W., *Dynamic characteristics of a coupled journal and thrust hydrodynamic bearing in a HDD spindle system due to its groove location*. Springer Verlag, *Microsystem Technologies*, 8, pp. 261-270, 2002.
- [11] Liu, L. X., Spakovszky, Z. S., *Effects of Bearing Stiffness Anisotropy on Hydrostatic Micro gas Journal Bearing Dynamic Behavior*. ASME, *Journal of Engineering for Gas Turbines and Power*, Vol. 129, pp. 177-184, 2007.
- [12] Wierzcholski, K., *Bio and slide bearings; their lubrication by non-Newtonian fluids and application in non-conventional systems*. Vol.I, Second Edition: *Principles of Human Joint Lubrication*. Monograph, Gdańsk University of Tech., 2006.
- [13] Wierzcholski, K., Miszczak, A., *Flow on the bio cell surfaces as an element of the micro-bearing tribology*. *Journal of Kones Powertrain and Transport*, Vol. 14, No. 2, pp. 553-560, 2007
- [14] www.oce.pg.gda.pl/biobearing/?path=8, 2006.
- [15] Yong-Bok, Lee, Hyun-Duck, Kwak, Chang-Ho-Kim, Nam-Soo, Lee, *Numerical prediction of slip flow effect on gas-lubricated journal bearing for MEMS/MST- based micro-rotating machinery*. *Tribology International*, 38, pp. 89-96, 2005.

